

Product Manual

Glue Applicators MS 80 and MS 200



Table of Contents

Product Description	1
General Safety Instructions	2
Safety Measures to be taken during Operation	3
Start-up and Control	4
Cleaning and Maintenance	6
Trouble-Shooting	7
Environmental Protection	8
Additional Information	8
EU Declaration of Conformity	9
Spare Parts	10
Technical Data	11

MS 80

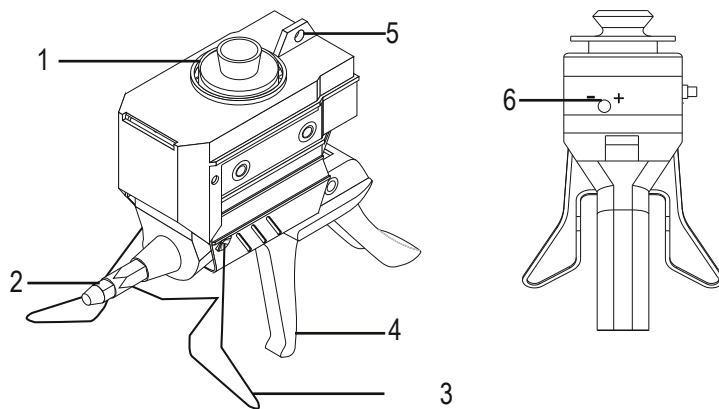

No.	Description
1	Lid
2	Nozzle
3	Wire Stand
4	Trigger
5	Plug
6	Screw for Temperature Regulation

MS 200

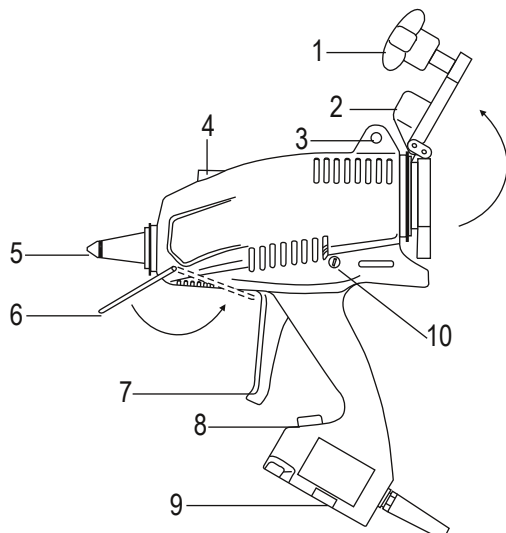

No.	Description
1	Star Grip
2	Lid
3	Plug
4	Screw for Temperature Regulation
5	Nozzle
6	Wire Stand
7	Trigger
8	On/Off Switch
9	Magnet
10	Screw for Adjusting Trigger

Product Description



Dear customer,

the glue applicator you purchased will help you to glue parts together more easily and more rapidly. To ensure an optimum usage of the glue applicator we recommend that you read these instructions thoroughly before using the applicator for the first time. The following illustration shows where to find the serialnumber of the applicator:

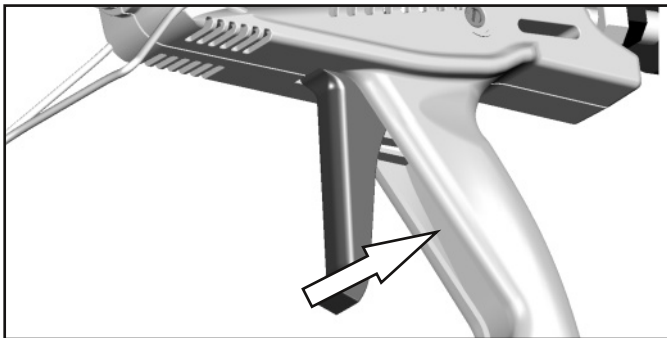

MS 200



MS 80

Eggenstein-Leopoldshafen, Germany, June 18th 2013

Intended Use

The applicator works with non reactive hot-melt glue which is dispensed by a mechanical conveying system. It is suitable for hot-melt from 1000 up to 15.000 mPas*. Therefore, this glue applicator should only be used by trained, instructed and authorized persons who have been familiarized with the proper use and the safety precautions. Handling the applicator properly will avoid unnecessary accident hazards and problems.

Bodily injury or material damage caused by not using the glue applicator as intended shall not be the manufacturer's, but the user's responsibility.

*less than 1000 and more than 15.000 mPas possible with limitations.

General Safety Instructions

Care and Diligence of the User

The glue applicator has been designed and fabricated in conformity with the applicable harmonized standards and additional technical specifications. So, it is state of the art and ensures maximum safety. This safety, however, can only be achieved in the operational practice, if all the necessary measures are taken. The user of the equipment shall be obliged to plan these measures and to make sure that they are taken.

In particular, the user shall ensure that

- the applicator to be used is in good working order
- the personal protective equipment (protective gloves, safety goggles) required for the operating personnel is available and used
- the operating instructions are in legible condition and available to the operator
- only sufficiently trained and authorized personnel operates and maintains the applicator
- this personnel is regularly instructed in the applicable regulations of operational safety and environmental protection and knows the operating instructions and, in particular, the included safety instructions.

Making the Information available

This operating manual shall always be kept at the place of operation of the applicator. Be sure that all persons handling the applicator can consult the instructions at any time. In addition to this operating manual, there must be available instructions regarding legal and other mandatory regulations relating to accident prevention and to relevant requirements of the employers' liability insurance association.

Safety Symbols

This operating manual gives concrete safety instructions to alert the user to remaining unavoidable hazards.

These hazards imply dangers to

- persons
- product and equipment

Meaning of the used Symbols



This symbol indicates that there is, above all, danger to persons, but also to equipment and material



Caution: hot surface! Accident Prevention Regulation VBG 125 – W26 Hot surfaces such as machine parts, tanks or materials, but also hot liquids cannot always be perceived. The utmost caution is advised when this symbol is attached to a component. Wear protective gloves whenever you have to touch hot surfaces.



To avoid accidents lay the cables so that they will not cause any risk of stumbling.



Wear protective gloves and safety goggles whenever you work with the applicator.



Safety Measures to be taken during Operation



The equipment must only be used by trained, instructed and authorized persons. These persons must have read the operating instructions and be able to work accordingly. Before using the applicator, check it for visible damage and make sure that it is only used when in proper and safe condition. Notify detected defects to the appropriate person immediately.

Safety Instructions for the Operation



Wear protective gloves and safety goggles whenever you work with the applicator.



Do not leave the device unattended.



Avoid accidents by stumbling – Lay all cables, hoses and conducts so that they will not cause any risk of stumbling. For this, install cable ducts and bridges.



MS 200 only: The device uses a super magnet. Keep magnets away from all items and objects which can be damaged by strong magnetic fields.



Magnets can influence the functionality of pacemakers.

Overfilling can cause hot-melt after it melted to exit the tank. This is why glue should only be filled up to the marker.

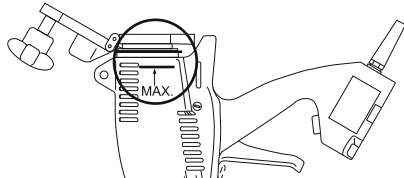

Never exceed the operating temperature of the hot-melt. This temperature is indicated in the technical datasheet of the hot-melt. Overheating may lead to decomposition which may affect the health of the user as well as the operability of the applicator.

The heating temperature should be lowered during longer work breaks to preserve the hot-melt. Ongoing heating makes the hot-melt coke and may also change its characteristics.

Once the applicator has warmed up, nozzle and lid are very hot.

Never start working before fitting a nozzle first.

Only replace nozzle when applicator is warmed up.

Unplug the connecting cable, before replacing a nozzle.

Warning: risk of burns! When a nozzle is replaced, liquid glue might leak out.

Never bring the hot nozzle into contact with the cable.

Never direct the glue jet towards people.



If hot glue comes into contact with the skin, cool it with cold water immediately. Do not try to remove the hot-melt from the skin first. If necessary, consult a doctor. If hot glue comes into contact with the eyes, immediately cool them under running water for about 15 minutes and consult

your doctor at once.

Always deposit the glue applicator on the wire stand or the respective plate destined for this purpose.

Do not lay the applicator on its side.

Do not hold nozzle top upward for too long. If you do hold it upward for too long, hot-melt will reach the lid and might flow out when the applicator is opened the next time.

Do not carry out overhead work.

Stop using the equipment immediately, if the casing is damaged due to shock, breakage or heavy wear.

Never clean the applicator with solvents, benzene, benzene, toluene, acetone, turpentine or paraffin. Risk of explosion!

Start-up and Control



Wear protective gloves and safety goggles whenever you work with the applicator.



Avoid accidents by stumbling – Lay all cables, hoses and conduits so that they will not cause any risk of stumbling. For this, install cable ducts and bridges.



Never direct the glue jet towards people!

Never lay the hot-melt applicator on its side.

Do not hold the nozzle top upward for too long.

Do not carry out overhead work.

Do not start working, before fitting a nozzle first.

Only replace nozzle when applicator is warm.

Only open the lid when the applicator has warmed up.

Do not overfill the applicator.

Stop using the equipment immediately, if the casing is damaged due to shock, breakage or heavy wear.

The glue applicator must only be used/applied for its intended purpose. Please read the chapter „General Safety Instructions“. If it is not used as intended, this may cause bodily injuries or equipment damages. Disregard of the safety instructions for the use of the applicator may lead to serious burns.

Switch Applicator on/off

MS 80: The device starts heating up as soon as it is plugged in. Unplug it to turn it off.

MS 200: An illuminated on/off-switch indicates that the applicator is switched on. Press the switch in order to turn the applicator on or off.

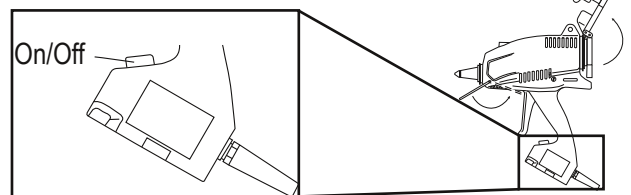

Minor leaking while the applicator is warming up is due to the hot-melt expanding in the nozzle and heating chamber.

Adjust Temperature

The glue guns MS 80 and MS 200 are factory set to heat up to approximately 200 °C when switched on.

MS 80: The temperature adjusting-screw can be found at the back side of the applicator.

MS 200: The temperature adjusting-screw can be found at the upper side of the applicator.

The temperature can be adjusted by turning the adjusting-screw with a screw driver. The right-end stop is the maximum temperature of 200 °C. Never turn the screw with force! This will lead to damaging the applicator. In order to lower the working temperature, turn the adjusting screw counter clockwise.

To check the temperature an external thermometer is needed (not included in delivery).

Adjusting the trigger (MS 200 only)

The adjustment of the trigger has influence on the lever stroke and on how much glue can be dispensed at once. A screwdriver can be used to turn the adjustable screw on the left side of the applicators' casing. The longer the lever stroke, the more glue can be dispensed at once and vice versa.

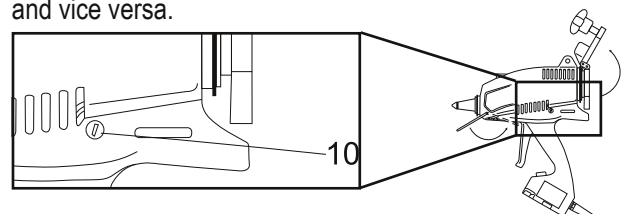

Start-up and Control



Loading Hot-Melt

The MS 200 glue applicator must only be used to dispense non-reactive hot-melts with a viscosity of 1000 up to 15.000 mPas*. Never feed other materials, dirt or sharp objects like small fragments of metal. The hot-melt glue applicator is only capable of working with all non-reactive hot-melt types which are designed for working temperatures of up to max. 200 °C.

Only open and close the lid when the hot-melt applicator is heated up. Otherwise the closing mechanism could be damaged.

MS 80

After the end of the heat-up period (approx. 10 min.), open the lid and load granulate up to just under the lower rim of the feeding opening. Close the lid and allow the applicator to melt the glue.

MS 200

After the end of the heat-up period (approx. 5 min.), open the lid by turning the star grip counter clockwise.

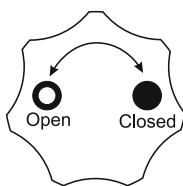

Load granulate up to 1,5 cm (~ 0.6 inch) under the lower rim of the feeding opening.



Shut the lid, turn the stargrip clockwise until the lid is fully closed.



Caution: Make sure the lid is shut securely, otherwise hot-melt may flow out.

When the star grip is overturned / over tightened the closing mechanism could be damaged.

*less than 1000 and more than 15.000 mPas possible with limitations.

Applying Hot-Melt



Wear protective gloves and safety goggles whenever you work with the applicator.



Never start working before fitting a nozzle first.



Never direct the glue jet towards people!

Do not start working before the glue has molten. Partially molten glue is thick and it needs a lot of force to press it off the applicator. Doing so would damage the applicator.

Always deposit the glue applicator on the wire stand or the respective plate destined for this purpose.

The glue applicator must not be laid on its side.

Do not open the lid before the applicator has warmed up.



If hot glue got into contact with your skin, cool it with cold water immediately. Do not try to remove the hot-melt from the skin first. If necessary, consult a doctor. If hot glue comes into contact with the eyes,

immediately cool them under running water for about 15 minutes. Consult your doctor at once!

Always keep the working temperature of the specific hot-melt glue (see "Adjust Temperature"). This temperature is indicated in the technical datasheet of the hot-melt glue. Make sure the hot-melt is melted. Make yourself familiar with the applicator first. Apply a little glue in varying forms on a piece of paper or cardboard; for example dots and lines.

The quantity to be applied is determined by pulling the trigger: the more you pull the more glue flows out.

Start-up and Control

Picking up/putting down the Applicator

MS 200: The MS 200 can be put down and picked up comfortably on magnetic surfaces by using the magnetic foot.

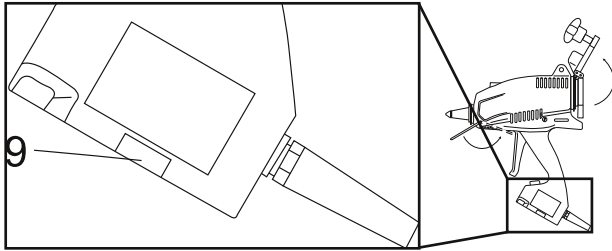

MS 80 & MS 200: The glue guns have a wire stand which is used to put down the applicator. Reka recommends folding in the wire stand when working with the applicator.

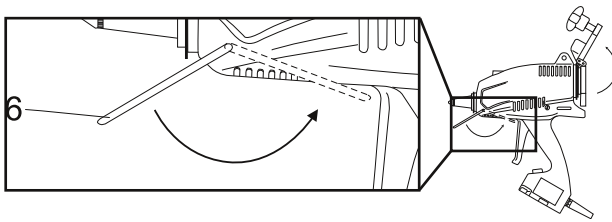

Replacement of Nozzles



Warning: risk of burns! If hot glue got into contact with your skin, cool it with cold water immediately. Do not try to remove the hot-melt from the skin first. If necessary, consult a doctor. If hot glue comes into contact with the eyes, immediately cool them under running water for about 15 minutes. Consult your doctor at once!



For your own safety: wear protective gloves and safety goggles when you replace nozzles.



Always unplug the applicator before replacing a nozzle!

Only replace nozzles when the glue applicator is warm (instrument temperature 60 – 80 °C) and empty. Replacing a nozzle when the applicator is cold may damage the equipment. Replacing the nozzle when the applicator is too hot, causes liquid glue to flow out. The melting range as well as the melting point of the used glue may be taken from the technical datasheet of the respective glue.

Cleaning and Maintenance

Never fill soiled glue into the melting tank. If you observe all advices given in the operating manual, the glue applicator does, normally, not need cleaning. The non-reactive glue contained in the applicator will remelt and can be used for gluing again. The working temperature of the respective glue may be taken from the technical datasheet which can be procured from the producer of the glue. This temperature must not be exceeded, otherwise the glue may coke in the glue applicator. Hot-melts on a polyamide basis are particularly sensitive. If a special cleaning agent is needed, information on this cleaning agent is available at your glue supplier.



Never clean the applicator with solvent, benzine, benzene, toluene, acetone, turpentine etc., risk of explosion!

The applicator is to be maintained by skilled personnel on a regular basis. The frequency of maintenance depends on wear and the hot-melt in use. Checks and maintenance should include, but are not limited to, functionality of the closing mechanism, the wire stand, the magnet and the power cord. In case of a non-functional closing mechanism hot-melt can leak from the glue gun. The lid and the venting hole in the lid need to be free of hot-melt.

Trouble-Shooting



List of possible fault indications and assistance in trouble-shooting

In case of damage, send the glue applicator to your supplier or directly to Reka indicating type and serial no. of your applicator. Self-made repairs void the warranty.

Fault	Possible Cause	Measures to be taken
No or too little glue output, though the heat-up time has been observed exactly	<ul style="list-style-type: none">• Foreign objects in nozzle?• Low hot-melt temperature	<ul style="list-style-type: none">• Replace nozzle• Check temperature setting
Hot-melt is too thin or too viscous	<ul style="list-style-type: none">• Temperature of hot-melt is too low or too high	<ul style="list-style-type: none">• Check temperature setting
Hot-melt contains brown flakes	<ul style="list-style-type: none">• Hot-melt was heated over recommended temperature• Hot-melt was heated for too long and is coked	<ul style="list-style-type: none">• Lower the heating temperature• Lower the heating temperature during work breaks
Leaking nozzle	<ul style="list-style-type: none">• Foreign objects in nozzle?• Glue clogs venting hole at the lid?	<ul style="list-style-type: none">• Replace nozzle• Clean lid
Applicator doesn't heat up	<ul style="list-style-type: none">• Device is switched off• Thermostat is turned to left-end stop	<ul style="list-style-type: none">• Check power supply• Turn on applicator, if applicable (MS 200).
Hot-melt is leaking out of casing	<ul style="list-style-type: none">• O-rings at the piston are worn out	<ul style="list-style-type: none">• Stop using device immediately• Send in device for repair

Environmental Protection

Never throw electric tools in the domestic waste. According to the European directive 2002/96/EC for used electric and electronic devices and according to national regulations, used electric tools must be collected separately and treated in an environmentally compatible way for re-use.

Packing material used by Reka Klebetechnik can be recycled completely.

Please take instructions for the disposal of hot-melt glues and hot-melt cartridges from the respective safety specifications.



Additional Information

Do you have any more questions or requests? We will be glad to help you.

Please contact us by:

Telephone +49 721 970 780

Telefax +49 721 705 069

E-Mail sale@reka-klebetechnik.de

Our mailing address is:

Reka Klebetechnik GmbH & Co. KG

Siemensstr. 6

DE-76344 Eggenstein

Internet: <http://www.reka-klebetechnik.de>

EU Declaration of Conformity



Product: Hot-Melt Glue Applicator

Type:

MS 80

MS 200

This is to certify that the above applicators in the design marketed by us are in conformity with the following EC directives:

Until 15-01-2007: 73/23/EEC, from 16-01-2007: 2006/95 EC
until 19-07-2009: 91/368 EEC, from 20-09-2009: 2004/108 EC
until 28-12-2009: 89/336 EEC, from 29-12-2009: 2006/42 EC
2002/95/EC

The following standards have been applied:

IEC CISPR14
IEC 60335
IEC 60204
IEC 61000

This declaration of conformity shall get invalid, if the product is modified, extended, or otherwise changed without express approval of Reka Klebtechnik

- and/or other components than accessories of Reka Klebtechnik are fitted,
- and if the product is not connected or used as intended.

Eggenstein-Leopoldshafen, June 18th 2013

A handwritten signature in black ink that reads "Christa Armbruster".

Christa Armbruster

Management Purchasing and Production
Reka Klebtechnik GmbH & Co. KG

Spare Parts

MS 80

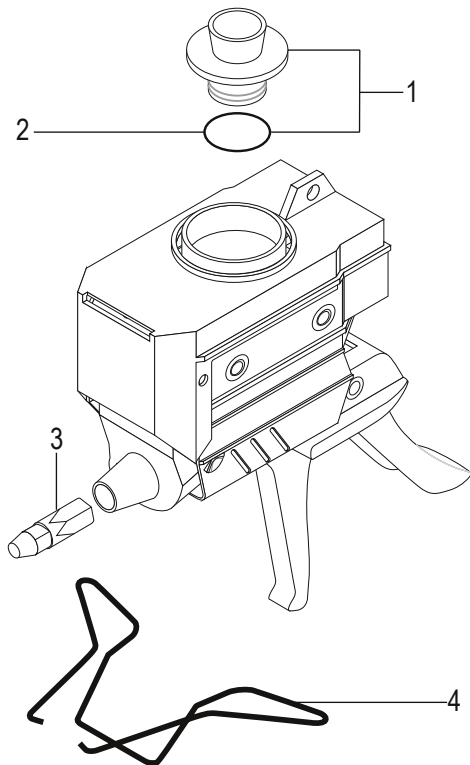

No.	Description	Article No.
1	Lid MS 80 cpl.	3885
2	O-Ring 28x3,5	3827
3	Nozzle 1,75mm	3911
4	Stand MS80	3882

MS 200

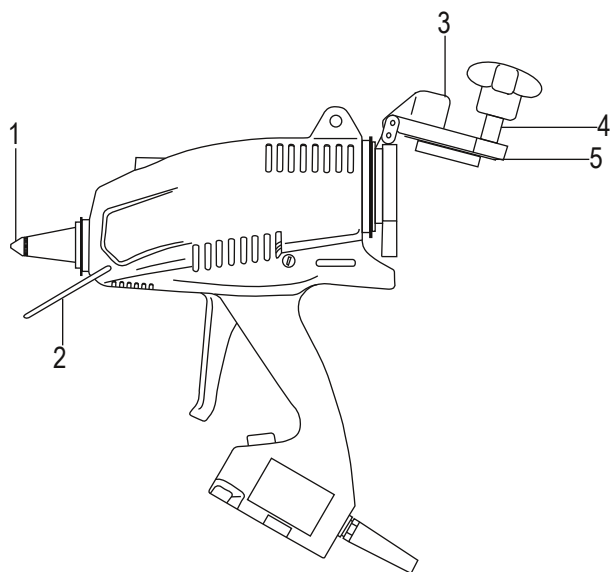

No.	Description	Article No.
1	Nozzle 2,0mm	2977
2	Wire Stand MS 200	3345
3	Lid MS 200 cpl. (incl. O-Ring 40x3 / 2603)	3436
4	Locking MS 200 cpl.	3438
5	O-Ring 40x3	2603

Wear & Tear Set MS 200 3442
(2 x Nozzle 2,0mm, 5 x O-Ring 40x3)

Technical Data



	MS 80	
Article Number	5551 (230 V)	5560 (120 V)
Weight	850 g	
Power Supply	230 V / 50 Hz	120 V / 60 Hz
Power Consumption	200 Watt	200 Watt
Current Consumption	0,9 A	
Degree of protection	I	
Class of protection	IP 30	
Temperature control	Thermostat	
Operating temperature	20 – 200 °C	
Consistency of temperature	+ - 5 °C	
Heat-up time	approx. 10 min.	
Gross Tank Capacity	150 ml	
Conveying system	Mechanics	
Length of electric cord	1,8 m	
Recommended melts	Hot-melt granulate, pillows and chips	

	MS 200	
Article Number	5579 (230 V)	5580 (120 V)
Weight	1220 g	
Power Supply	230 V / 50 Hz	120 V / 60 Hz
Power Consumption	500 Watt	500 Watt
Current Consumption	2,6 A	
Degree of protection	I	
Class of protection	IP 30	
Temperature control	Thermostat	
Temperature limitation	Temperature monitor	
Operating temperature	20 – 200 °C	
Consistency of temperature	+ - 5 °C	
Heat-up time	approx. 5 min.	
Gross Tank Capacity	250 ml	
Conveying system	Mechanics	
Length of electric cord	1,8 m	
Recommended melts	Hot-melt granulate, pillows, chips and 43mm sticks/slugs	

Reka Klebetechnik GmbH & Co. KG
Siemensstraße 6
DE-76344 Eggenstein

Telephone +49 721 970 780
Telefax +49 721 705 069

E-Mail: sale@reka-klebetechnik.de
Internet: <http://www.reka-klebetechnik.de>